

# Ditec DAB805PLAB

IP2171

Istruzioni braccio scorrevole per vie di fuga

Instructions for sliding arm for escape routes

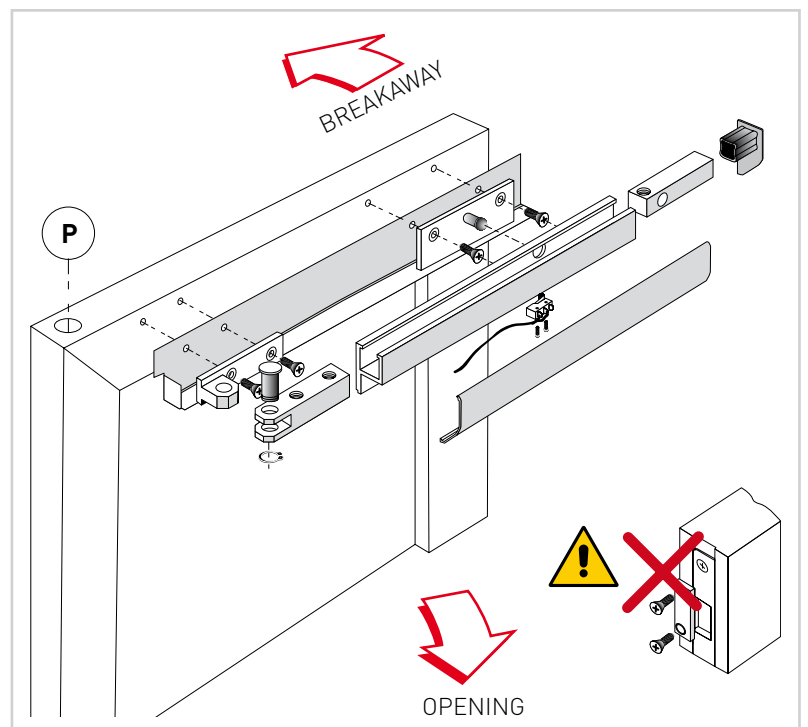
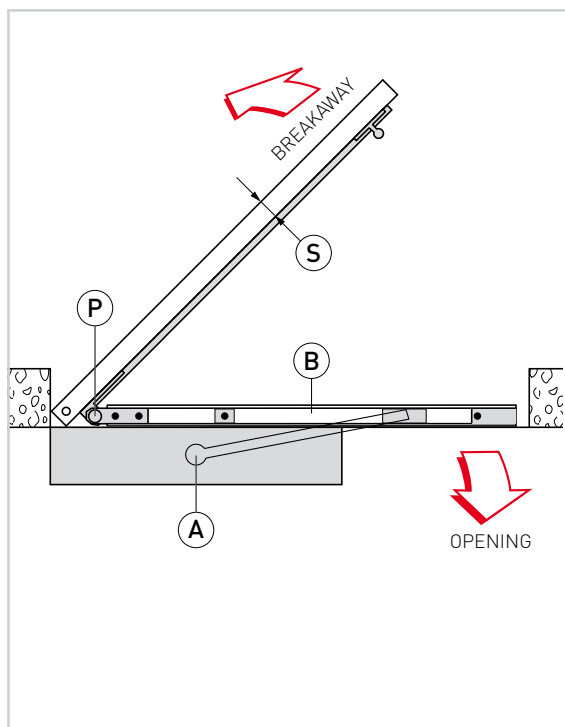
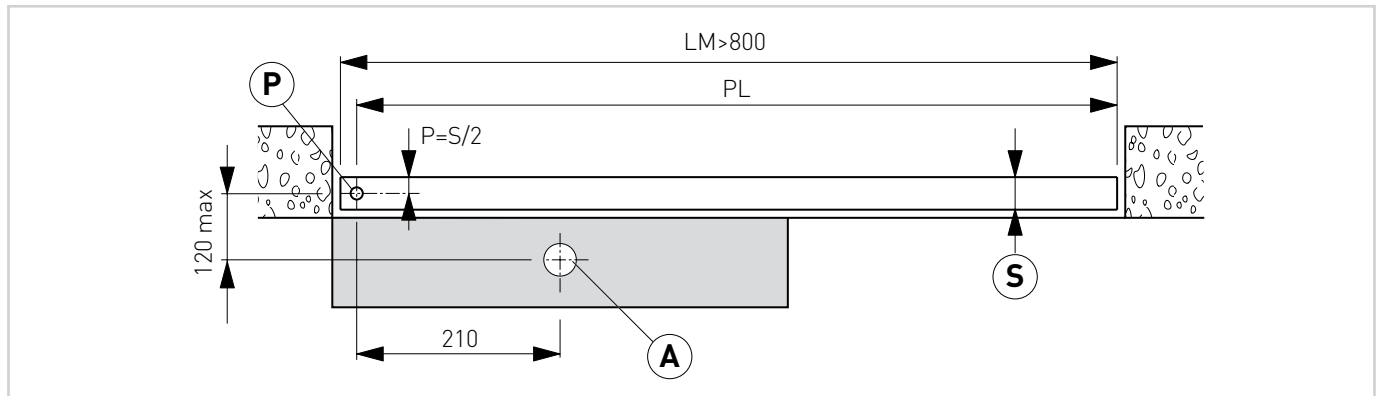

Rif/Ref	Descrizione	Description
1	Supporto antipánico	Anti-panic support
2	Cerniera	Hinge
3	Incontro	Striker plate
4	Guida braccio antipánico	Anti-panic arm guide
5	Scontro antipánico	Anti-panic strike
6	Micro interruttore	Microswitch
7	Copri guida	Guide cover
8	Testata	Head

# 1. Predisposizioni



Per le predisposizioni fare riferimento al capitolo 8 del manuale di installazione DAB105.

# 2. Fissaggio automazione



Per l'installazione dell'automazione fare riferimento al capitolo 8 del manuale di installazione DAB105.

# 3. Fissaggio braccio

- Con porta chiusa, fissare il braccio all'automazione nella sede supporto braccio [A], vedi figura pagina 1.
- Fissare il braccio come indicato di seguito.

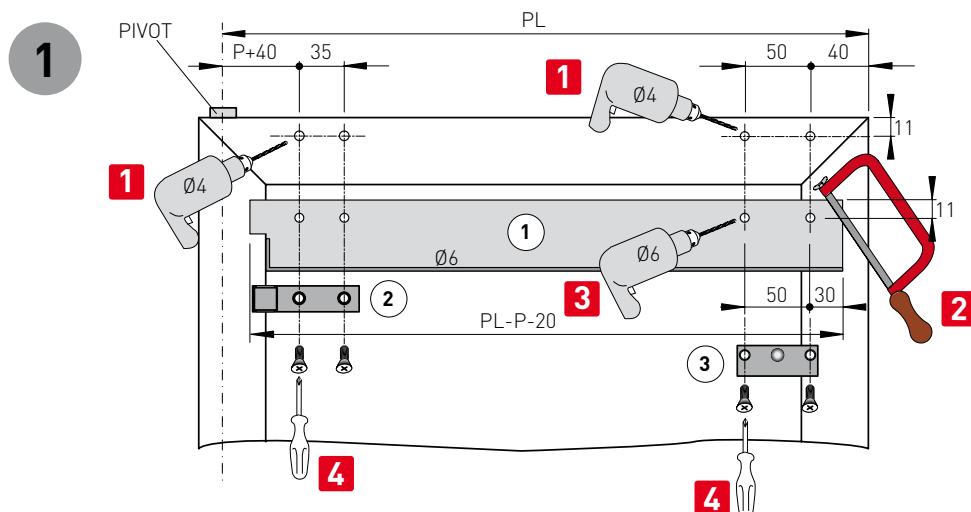

1. Forare l'anta Ø4 come indicato in figura.
2. Tagliare a misura il supporto antipatico [1].
3. Forare Ø6 il supporto antipatico [1]
4. Fissare il supporto antipatico [1], la cerniera [2] e l'incontro [3] all'anta con le viti in dotazione.

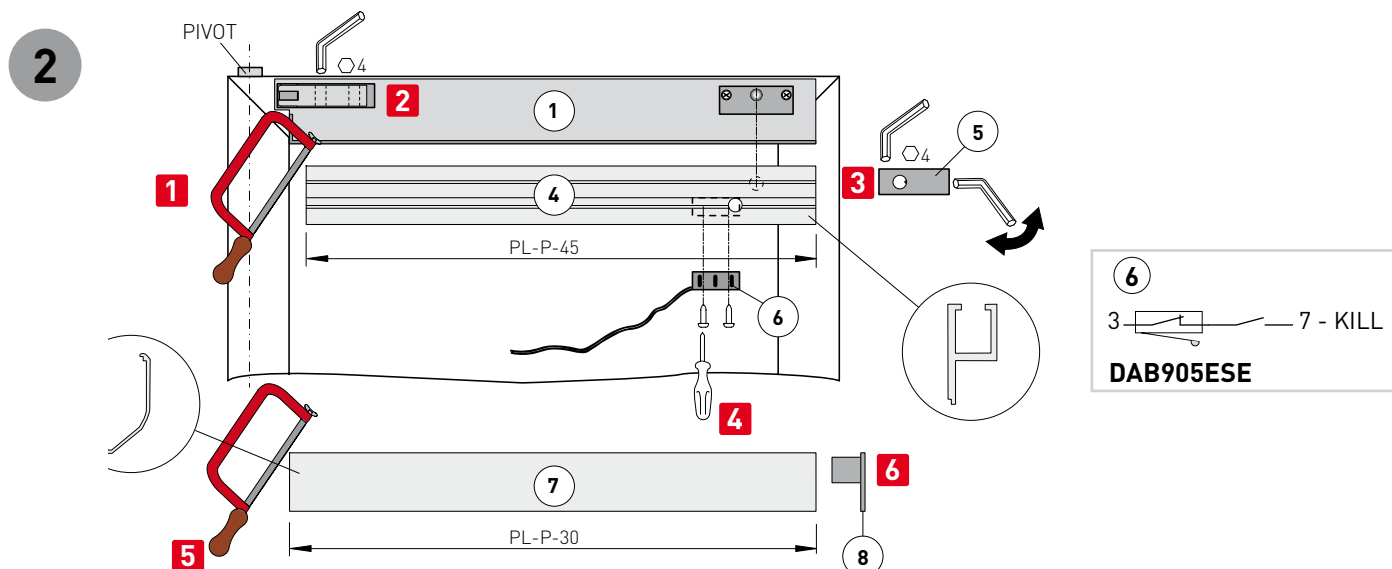

1. Tagliare a misura la guida braccio antipatico [4].
2. Agganciare la guida braccio antipatico [4] sul supporto antipatico [1].
3. Introdurre lo scontro antipatico [5] all'interno della guida braccio [4].
4. Fissare il micro interruttore [6] alla guida braccio antipatico [4], e collegarlo ai morsetti 3-7 della scheda aggiuntiva DAB905ESE.
5. Tagliare il copri guida [7] a misura e agganciarlo sulla guida braccio antipatico [4].
6. Fissare la testata [8] sulla guida braccio antipatico [4].



Per ulteriori regolazioni fare riferimento al manuale di installazione DAB105

# 1. Pre-installation

**i** For the fittings, refer to chapter 8 of the DAB105 installation manual.

# 2. Fastening the automation

**i** For the installation of the automation, refer to chapter 8 of the DAB105 installation manual.

# 3. Fastening the arm

- With the door closed, fix the arm in its support on the automation [A] - see the figure on page 1.
- Fix the arm, as indicated below.

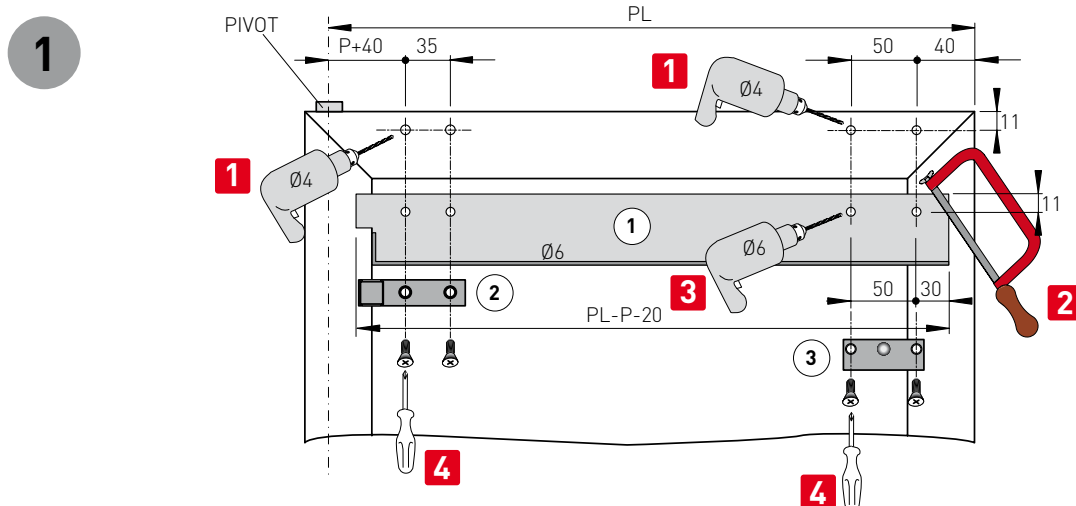

1. Drill a hole Ø4 in the door wing, as shown in the figure.
2. Cut the anti-panic support [1] to size.
3. Drill a hole Ø6 in the anti-panic support [1]
4. Fix the anti-panic support [1], hinge [2] and striker plate [3] to the door wing, using the screws supplied.

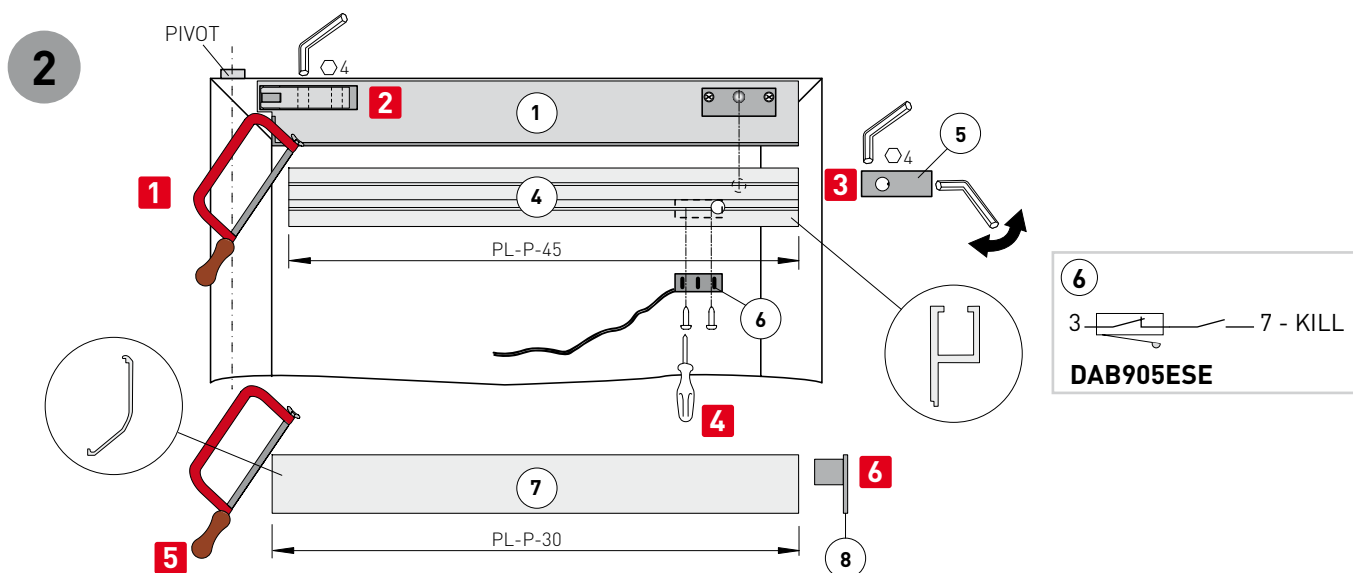

1. Cut the anti-panic arm guide [4] to size.
2. Couple the anti-panic arm guide [4] with the anti-panic support [1].
3. Insert the anti-panic strike [5] in the arm guide [4].
4. Fix the microswitch [6] to the anti-panic arm guide [4], and connect it to the terminal 3-7 of DAB905ESE extension unit.
5. Cut the guide cover [7] to size, then couple it with the anti-panic arm guide [4].
6. Fix the head [8] on the anti-panic arm guide [4].

**i** For further information, refer to the DAB105 installation manual.

# 1. Préparations



Pour les préparations consulter le chapitre 8 du manuel d'installation DAB105.

# 2. Fixation de l'automatisme



Pour l'installation de l'automatisme consulter le chapitre 8 du manuel d'installation DAB105.

# 3. Fixation du bras

- Avec la porte fermée, fixer le bras à l'automatisme sur le siège de support du bras [A], voir figure à page 1.
- Fixer le bras comme indiqué ci-après.

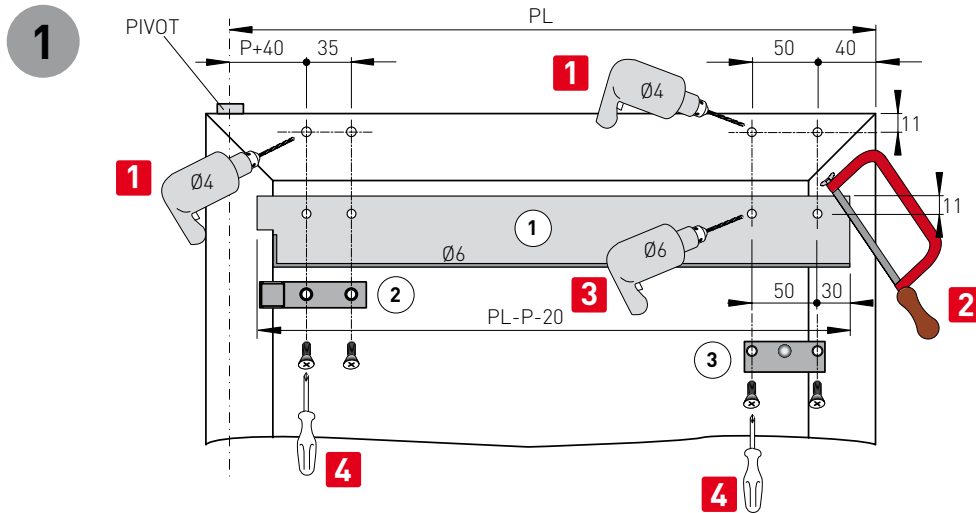

1. Percer le vantail Ø4 comme indiqué dans la figure.
2. Couper à la bonne mesure le support anti-panique [1].
3. Percer Ø6 le support anti-panique [1]
4. Fixer le support anti-panique [1], la charnière [2] et la butée d'arrêt [3] au vantail à l'aide des vis fournies.

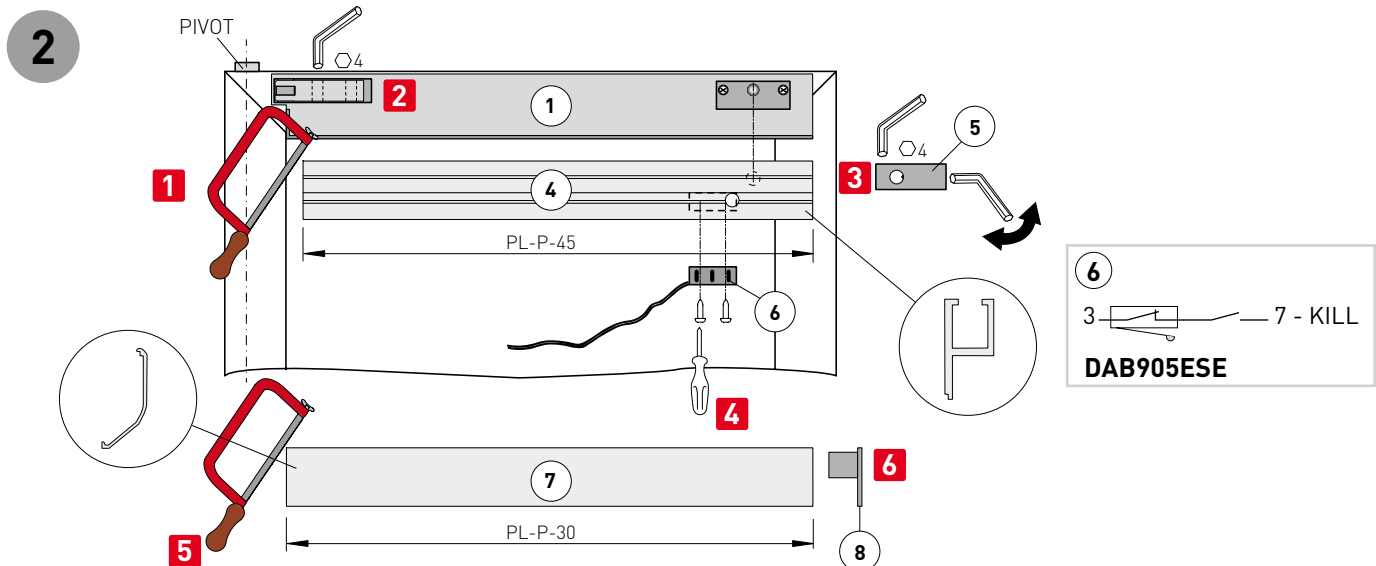

1. Couper à la bonne mesure le rail du bras anti-panique [4].
2. Accrocher le rail du bras anti-panique [4] sur le support anti-panique [1].
3. Introduire la butée d'arrêt anti-panique [5] à l'intérieur du rail du bras [4].
4. Fixer le micro interrupteur [6] au rail du bras anti-panique [4] et brancher aux bornes 3-7 de la carte d'extension DAB905ESE.
5. Couper le cache du rail [7] à la bonne mesure et l'accrocher au rail du bras anti-panique [4].
6. Fixer la tête [8] sur le rail du bras anti-panique [4].



Pour plus d'informations consulter le manuel d'installation DAB105.

# 1. Vorbereitungen



Für die Vorbereitungen siehe Kapitel 8 des Installationshandbuchs DAB105.

# 2. Befestigung des Antriebs



Für die Installation des Antriebs siehe Kapitel 8 des Installationshandbuchs DAB105.

# 3. Befestigung des Arms

- Bei geschlossenem Tor den Arm am Antrieb im Sitz der Armhalterung [A] befestigen, siehe Abbildung Seite 1.
- Die Führung [B] am Flügel befestigen, wie nachstehend beschrieben, gegebenenfalls den überstehenden Teil der Führung abschneiden.

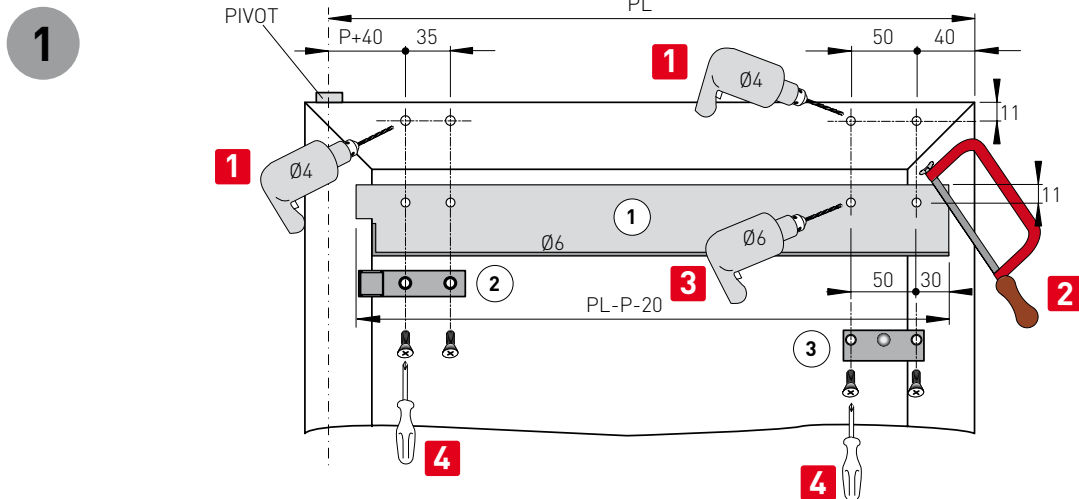

1. Ein Loch mit  $\varnothing 4$  in den Flügel bohren, wie aus der Abbildung ersichtlich.
2. Die Antipanikhalterung [1] auf das richtige Maß zuschneiden.
3. Ein Loch mit  $\varnothing 6$  in die Antipanikhalterung [1] bohren
4. Die Antipanikhalterung [1], das Scharnier [2] und das Schlossblech [3] mit den beige-packten Schrauben am Flügel befestigen.

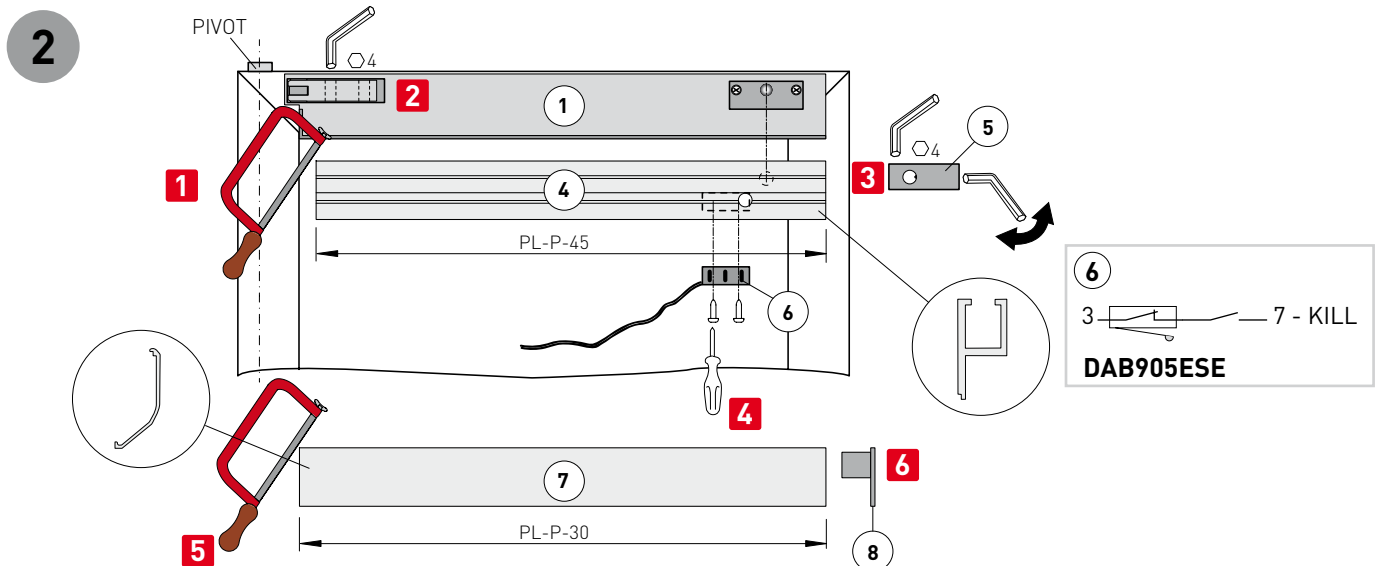

1. Die Antipanikarmführung [4] auf das richtige Maß zuschneiden.
2. Die Antipanikarmführung [4] an der Antipanikhalterung [1] einhaken.
3. Den Antipanik-Anschlag [5] in die Armführung [4] einführen.
4. Den Mikroschalter [6] an der Antipanikarmführung [4] befestigen, verbinden Sie an die Klemmen 3-7 des Add-in-Karte DAB905ESE.
5. Die Führungsabdeckung [7] zuschneiden und an der Antipanikarmführung [4] einhängen.
6. Den Kopfteil [8] an der Antipanikarmführung [4] befestigen



Für weitere Informationen wird auf das Installationshandbuch DAB105 verwiesen.

# 1. Predisposiciones

**i** Para las predisposiciones, consulte el capítulo 8 del manual de instalación DAB105.

# 2. Fijación del automatismo

**i** Para la instalación del automatismo, consulte el capítulo 8 del manual de instalación DAB105.

# 3. Fijación del brazo

- Con la puerta cerrada, fije el brazo al automatismo en el asiento del soporte del brazo [A], véase la figura de la página 1.
- Fije la guía [B] a la hoja como se indica a continuación; si fuera necesario, corte la parte que sobre de la guía.

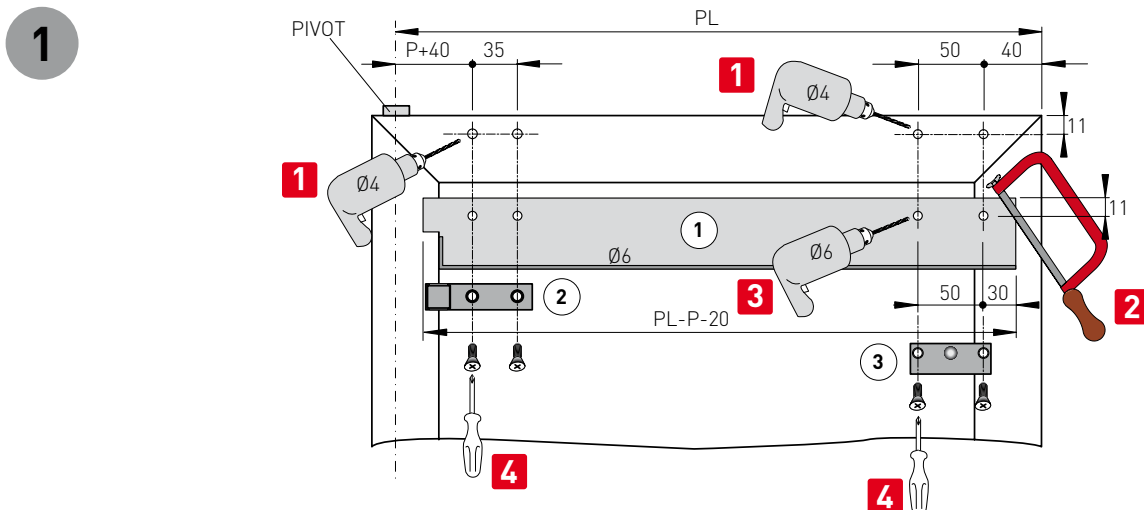

1. Perfore la hoja Ø4 como se indica en la figura.
2. Corte a medida el soporte antipánico [1].
3. Perfore Ø6 el soporte antipánico [1]
4. Fije el soporte antipánico [1], la bisagra [2] y el cierre [3] en la hoja con los tornillos suministrados.

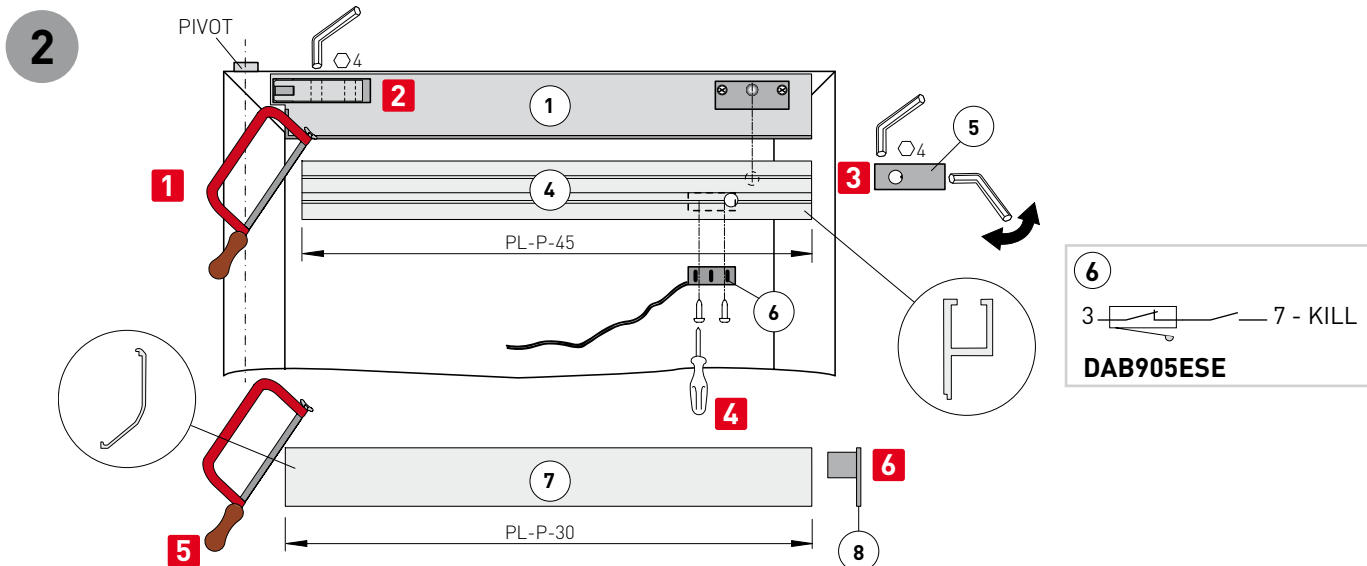

1. Corte a medida la guía del brazo antipánico [4].
2. Enganche la guía del brazo antipánico [4] en el soporte antipánico [1].
3. Introduzca el tope antipánico [5] en el interior de la guía del brazo [4].
4. Fije el microinterruptor [6] en la guía del brazo antipánico [4], y conectarlo a los terminales 3-7 del complemento DAB905ESE tarjeta.
5. Corte el cubreguía [7] a medida y engánchelo en la guía del brazo antipánico [4].
6. Fije el cabezal [8] en la guía del brazo antipánico [4].

**i** Para obtener más información, consulte el manual de instalación DAB105.

# 1. Predisposições

**i** Para as predisposições, consultar o capítulo 8 do manual de instalação DAB105.

# 2. Fixação do automatismo

**i** Para a instalação do automatismo, consultar o capítulo 8 do manual de instalação DAB105.

# 3. Fissaggio braccio

- Com a porta fechada, coloque o braço ao automatismo na sede de suporte do braço [A], consultar a figura na página 1.
- Fixe o braço como indicado a seguir.

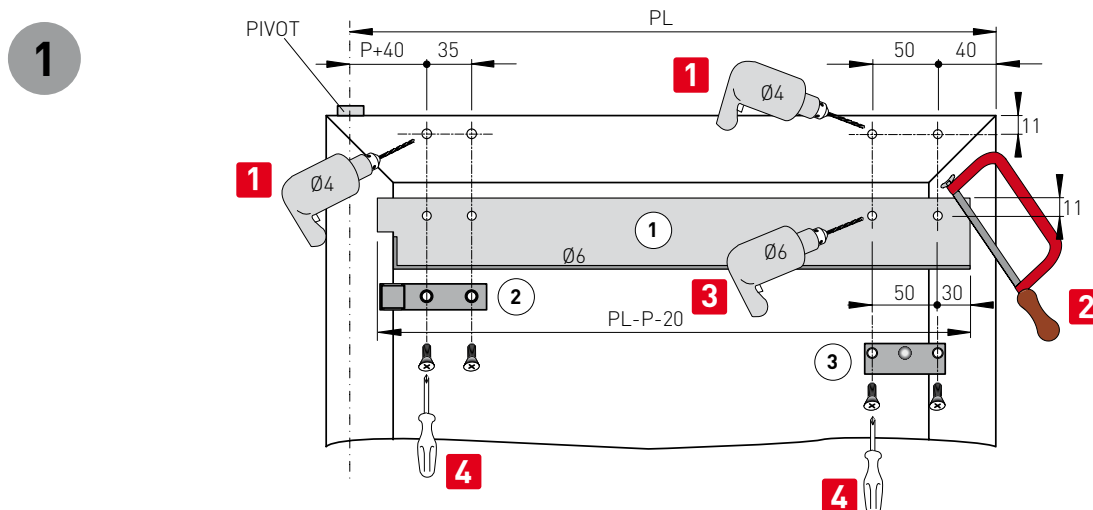

1. Fure a portinhola Ø4 como indicado na figura.
2. Corte sob medida o suporte antipânico [1].
3. Fure Ø6 o suporte antipânico [1]
4. Fixe o suporte antipânico [1], a dobradiça [2] e a junta [3] à portinhola com os parafusos fornecidos.

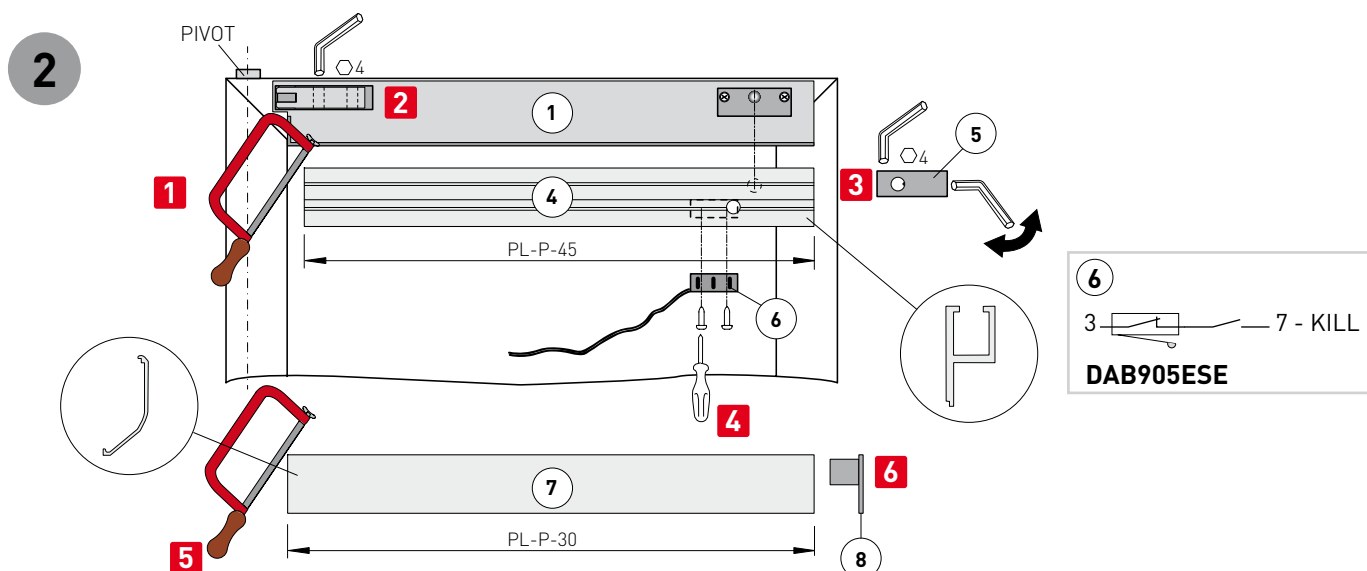

1. Corte sob medida a guia do braço antipânico [4].
2. Enganche a guia do braço antipânico [4] no suporte antipânico [1].
3. Introduza o batente antipânico [5] na guia do braço [4].
4. Fixe o microinterruptor [6] à guia do braço antipânico [4], conectar o micro a terminais 3-7 do add-in DAB905ESE cartão.
5. Corte a cobertura da guia [7] sob medida e enganche-a na guia do braço antipânico [4].
6. Fixe o cabeçote [8] na guia do braço antipânico [4].

**i** Para mais informações, consultar o manual de instalação DAB105.

Tutti i diritti relativi a questo materiale sono di proprietà esclusiva di Entrematic Group AB.

Sebbene i contenuti di questa pubblicazione siano stati redatti con la massima cura, Entrematic Group AB non può assumersi alcuna responsabilità per danni causati da eventuali errori o omissioni in questa pubblicazione.

Ci riserviamo il diritto di apportare eventuali modifiche senza preavviso.

Copie, scansioni, ritocchi o modifiche sono espressamente vietate senza un preventivo consenso scritto di Entrematic Group AB.

All rights related to this material are the exclusive property of Entrematic Group AB.

Although the contents of this publication have been compiled with the greatest possible care, Entrematic Group AB cannot accept liability for any damage that might arise from errors or omissions in this publication.

We reserve the right to make modifications without prior notice.

No part of this publication may be copied, scanned, adapted or modified without prior permission in writing from Entrematic Group AB.

Tous les droits relatifs à ce matériel sont la propriété exclusive d'Entrematic Group AB.

Bien que les contenus de cette publication aient été rédigés avec le plus grand soin, Entrematic Group AB ne saurait être tenue responsable en cas de dommages dérivant d'erreurs ou d'omissions éventuelles.

Nous nous réservons le droit d'apporter des modifications éventuelles sans préavis.

Toute copie, reproduction, retouche ou modification est expressément interdite sans l'accord écrit préalable d'Entrematic Group AB.

Alle Rechte an diesem Material sind ausschließliches Eigentum von Entrematic Group AB.

Obwohl der Inhalt dieser Publikation mit größter Sorgfalt erstellt wurde, kann Entrematic Group AB keinerlei Haftung für Schäden übernehmen, die durch mögliche Fehler oder Auslassungen in dieser Publikation verursacht wurden.

Wir behalten uns das Recht vor, bei Bedarf Änderungen ohne jegliche Vorankündigung vorzunehmen.

Kopien, Scannen, Überarbeitungen oder Änderungen sind ohne vorherige schriftliche Zustimmung von Entrematic Group AB nicht erlaubt.

Todos los derechos relativos a este material son propiedad exclusiva de Entrematic Group AB.

Aunque los contenidos de esta publicación se hayan redactado con la máxima atención, Entrematic Group AB no puede asumir ninguna responsabilidad por daños causados por eventuales errores u omisiones en esta publicación.

Nos reservamos el derecho de aportar eventuales modificaciones sin previo aviso.

Las copias, los escaneos, los retoques o las modificaciones están expresamente prohibidos sin el consentimiento previo por escrito de Entrematic Group AB.

Todos os direitos relativos a este material são de propriedade exclusiva da Entrematic Group AB.

Embora os conteúdos dessa publicação foram compilados com o maior cuidado, Entrematic Group AB não pode assumir qualquer responsabilidade por danos causados por eventuais erros ou omissões nessa publicação.

Reservamo-nos o direito de fazer alterações sem aviso prévio.

Cópias, digitalizações, alterações ou modificações são expressamente proibidas sem o consentimento prévio por escrito da Entrematic Group AB.

Entrematic Group AB  
Lodjursgatan 10  
SE-261 44, Landskrona  
Sweden  
[www.ditecentrematic.com](http://www.ditecentrematic.com)

**Ditec**  
**ENTRE//MATIC**

